

TAKING CARE OF UNEXPECTED PROBLEMS

SUBMERGED MOTOR

A submerged outboard motor must be serviced immediately after it is recovered from the water in order to minimize corrosion.

If there is a Honda marine dealership nearby, take the motor to the dealer immediately. If you are far from a dealership, proceed as follows:

1. Remove the engine cover, and rinse the outboard motor with fresh water to remove salt water, sand, mud, etc.
2. Drain the carburetors as described on p. 75 .

3. Change the engine oil as described on p. 59 . If there was water in the engine crankcase, or if the used engine oil showed signs of water contamination, then a second engine oil change should be performed after running the engine for half an hour.

4. Remove the spark plugs (p. 65), and remove the clip from the emergency stop or engine switch.

(Recoil starter type)

Pull the recoil starter grip, rotate the flywheel a few revolutions to completely expel any water from the cylinders.

(Electric starter type)

Remove the flywheel cover following the emergency starting procedure (p. 41) and pull the emergency starter rope, rotate the flywheel a few revolutions to completely expel any water from the cylinders.

EMERGENCY STARTER ROPE

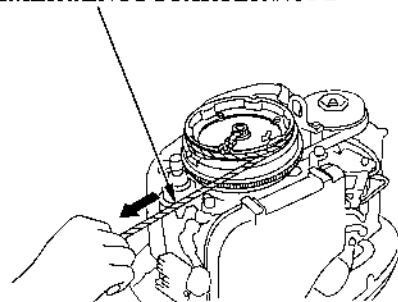

If the engine was running when it submerged, there may be mechanical damage, such as bent connecting rods. If the engine binds when cranked, do not attempt to run the engine until it has been repaired.