

DESCRIPTION

RUBBER MOUNTS AND SEALS

There are two exhaust housings: an inner housing or exhaust tube; and an outer housing enclosed by a combination of front and rear cover assemblies. The outer exhaust housing, which carries the power head by means of the adapter plate, "floats" inside the front and rear covers on five rubber mounts and the exhaust tube seal ring. Two of the rubber mounts support the adapter plate and power head at the top of the front exhaust cover, and the three other rubber mounts support the outer exhaust housing at the bottom of the front exhaust cover. In this way all power head and driveshaft vibrations are completely isolated and are prevented from being transmitted to the stern bracket and the boat transom. In addition, the rubber seal ring positions the outer exhaust housing within the rear exhaust cover and also prevents water and exhaust gases from rising above this point. See Figure 6-1.

SHOCK ABSORBERS

Two hydraulic shock absorbers are mounted between the swivel bracket and stern bracket to reduce the

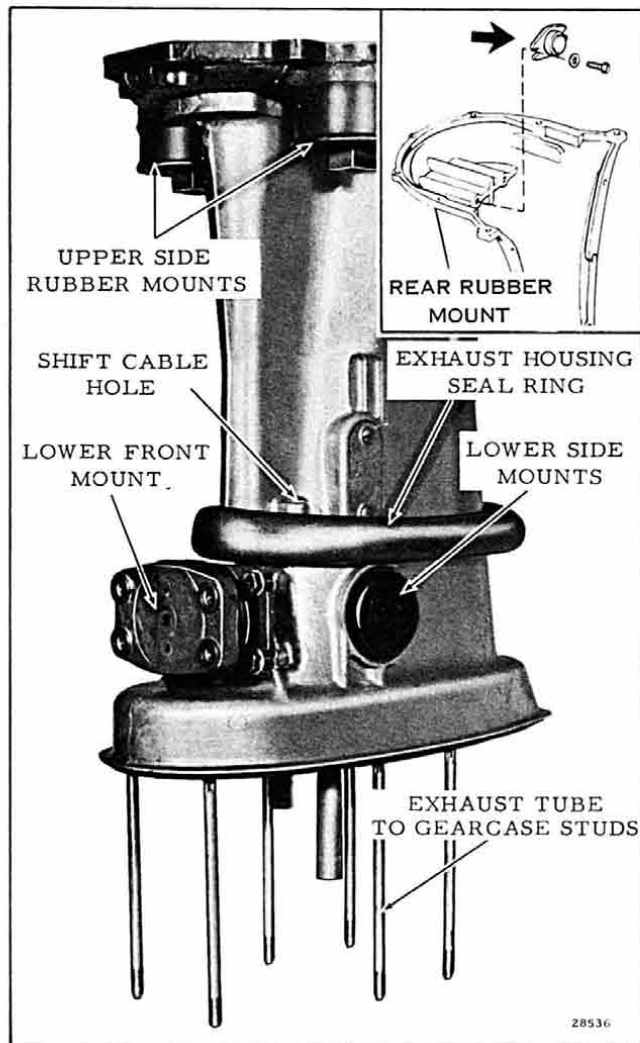

Figure 6-1. Rubber Mounts and Seals

shock resulting from hitting an underwater obstruction at high speed. The shock absorbers employ a tapered orifice which presents a greater resistance to motion at the full tilt position than at the normal position. See Figure 6-2.

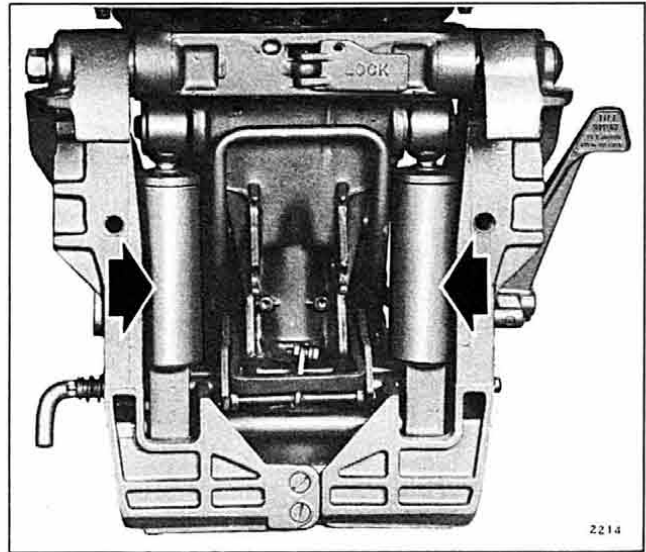

Figure 6-2. Shock Absorbers

In operation, upon hitting an underwater obstruction, the motor is allowed to tilt freely initially, but encounters greater resistance as it reaches full tilt position. After clearing the obstruction, the motor encounters decreasing resistance as it reaches normal position. Shock absorption throughout the full length of travel prevents the motor from slamming against the boat transom as it returns to normal position.

EXHAUST RELIEF

Normally, exhaust gases are conducted down through the exhaust housing and out the underwater outlet in the gearcase. The siphoning action of the propeller and water provides an unrestricted escape for exhaust. However, in starting, water in the outlet creates back pressure and hard starting. Exhaust relief is provided by another outlet located in the water discharge passage above the water line. Since no water is discharged until after the motor is started, the exhaust gases will initially be discharged through the exhaust relief. See Figure 6-3.

WATER PUMP

Water for cooling the power head is circulated by the water pump, located at the top of the upper gearcase and driven directly by the driveshaft. The pump consists of a synthetic rubber impeller which is keyed to the driveshaft, and the pump housing which is offset from center with respect to the driveshaft. Because the housing is offset, the impeller blades flex as they rotate, varying the space between them. The pump inlet port, located in the stainless steel plate which forms the lower part of the pump housing, is open to the blades when the space between them is increasing. The pump outlet port, in the impeller housing, is open to the blades when the space between